

EFFECTIVITY			REVISIONS			
S/N AND OP.	ZONE	REV	DESCRIPTION	E. C. NO	DATE	APPROVED
		A	CHANGED M-CODES		5-22-00	E.S.H.
			MACH. TYPE	S/N		

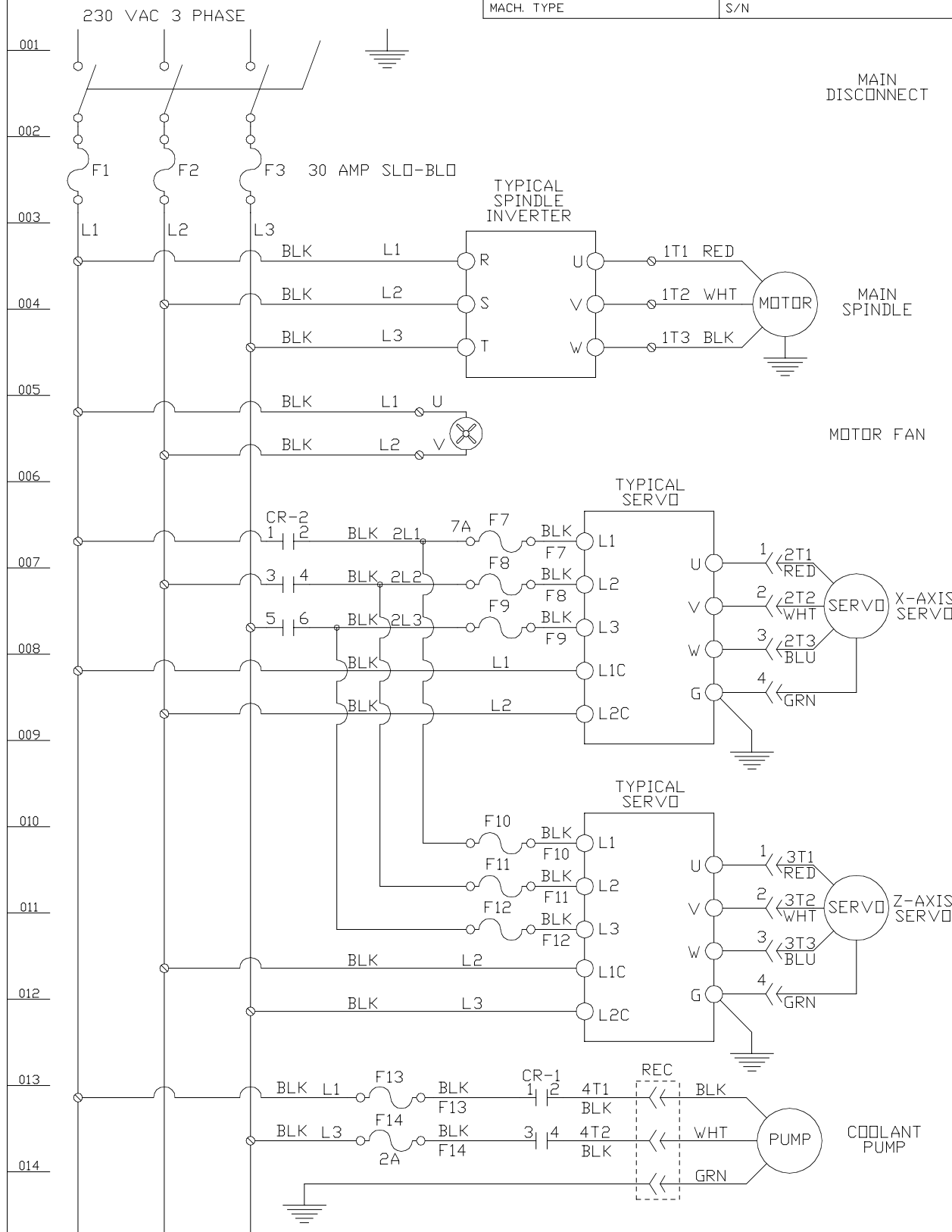

001  
002  
003  
004  
005  
006  
007  
008  
009  
010  
011  
012  
013  
014  
015  
016

230 VAC 3 PHASE

MAIN DISCONNECT

30 AMP SLD-BLO

TYPICAL SPINDLE INVERTER

MAIN SPINDLE

MOTOR FAN

TYPICAL SERVO

X-AXIS SERVO

TYPICAL SERVO

Z-AXIS SERVO

COOLANT PUMP

CONTINUED SHEET 2 LINES 17 & 18

THE INFORMATION SHOWN HEREON IS PROPRIETARY DATA OF UPGRADE TECHNOLOGIES WITH ALL RIGHTS AND TITLES RESERVED AND IS NOT TO BE USED FOR PRODUCTION OF PARTS SHOWN EXCEPT BY WRITTEN PERMISSION OF UPGRADE TECHNOLOGIES					
NAME	DATE	NAME	DATE		
DRAWN G.W.M.	5-30-00	ENG. E.S.H.	5-30-00	638 N. POINSETTA SANTA ANA, CA FAX (714) 664-0860	
CHK'D		APP'D E.S.H.	6-1-00	COMPACT MANUFACTURING SYSTEMS	
TITLE			E1-8055-01		
FAGOR 8055 ELECTRICAL SCHEMATICS			SCALE: NONE	REF. DVG. SHEET 1 OF 16	

EFFECTIVITY			REVISIONS			
S/N AND OP.	ZONE	REV	DESCRIPTION	E. C. NO	DATE	APPROVED
		A	CHANGED M-CODES		5-22-00	E.S.H.

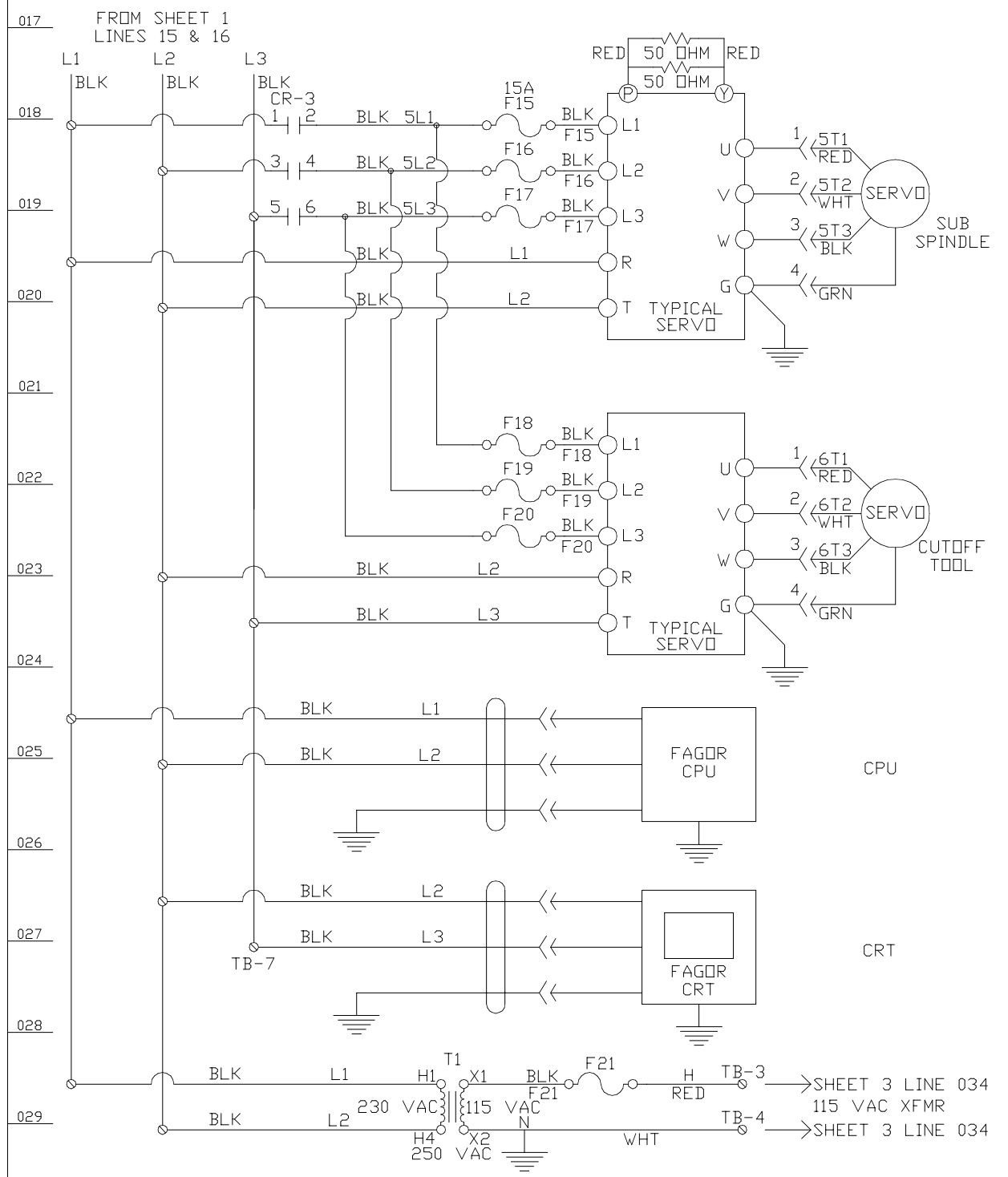

025 CPU  
026  
027 CRT  
028  
029 SHEET 3 LINE 034  
115 VAC XFMR  
SHEET 3 LINE 034

030

031

032

THE INFORMATION SHOWN HEREON IS PROPRIETARY DATA OF UPGRADE TECHNOLOGIES WITH ALL RIGHTS AND TITLES RESERVED AND IS NOT TO BE USED FOR PRODUCTION OF PARTS SHOWN EXCEPT BY WRITTEN PERMISSION OF UPGRADE TECHNOLOGIES					
NAME	DATE	NAME	DATE		
DRAWN G.W.M.	5-30-00	ENG. E.S.H.	5-30-00	638 N. POINSETTA SANTA ANA, CA FAX (714) 664-0860	
CHK'D		APP'D E.S.H.	6-1-00	COMPACT MANUFACTURING SYSTEMS CAD DWG SIZE B	
TITLE				E1-8055-01A	
FAGOR 8055 ELECTRICAL SCHEMATICS				REF. DWG. SHEET 2 OF 16	
				SCALE: NONE	

EFFECTIVITY			REVISIONS			
S/N AND OP.	ZONE	REV	DESCRIPTION	E. C. NO	DATE	APPROVED
		A	CHANGED M-CODES		5-22-00	E.S.H.

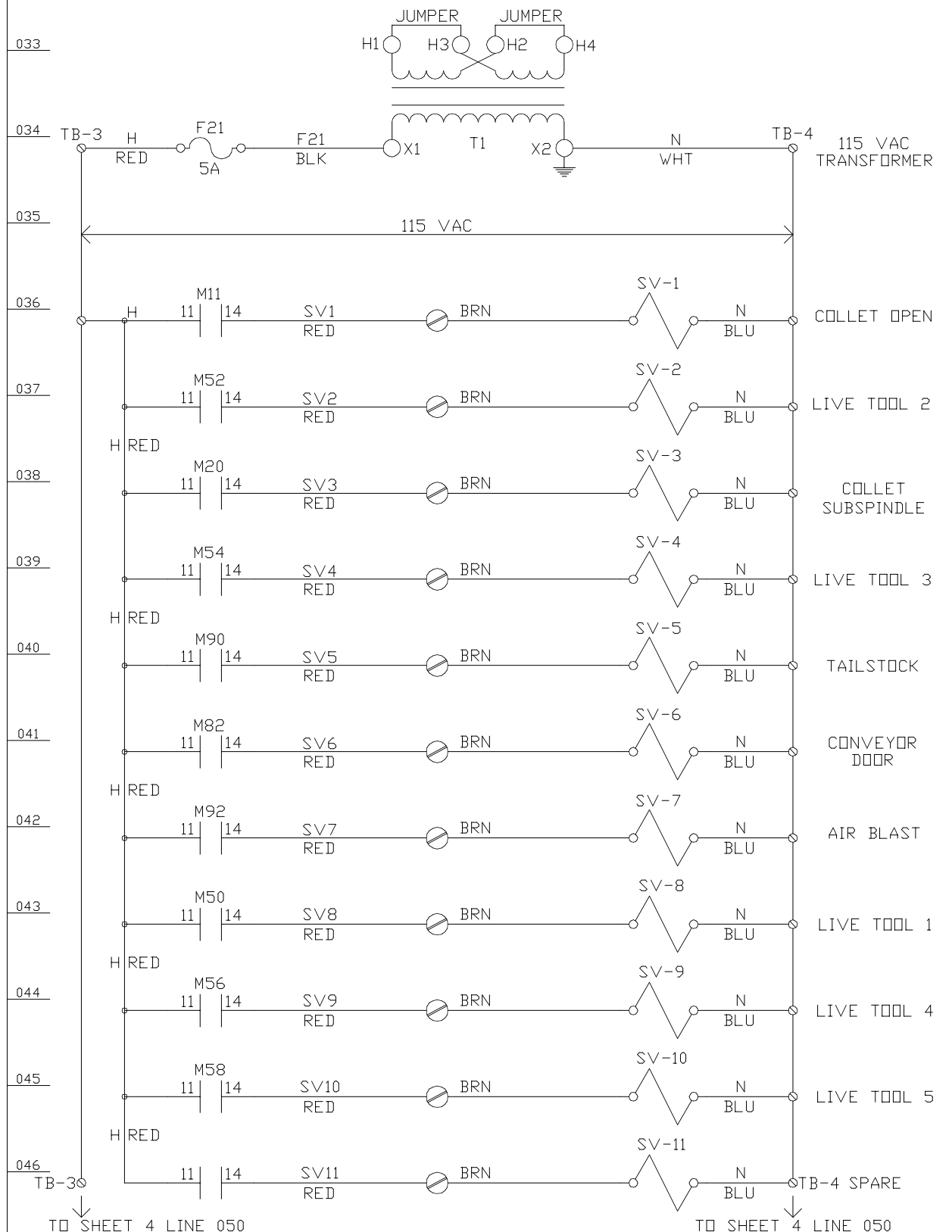

033

034

035

036

037

038

039

040

041

042

043

044

045

046

047

048

TO SHEET 4 LINE 050

TO SHEET 4 LINE 050

THE INFORMATION SHOWN HEREON IS PROPRIETARY DATA OF UPGRADE TECHNOLOGIES WITH ALL RIGHTS AND TITLES RESERVED AND IS NOT TO BE USED FOR PRODUCTION OF PARTS SHOWN EXCEPT BY WRITTEN PERMISSION OF UPGRADE TECHNOLOGIES

NAME	DATE	NAME	DATE
DRAWN G.W.M.	5-30-00	ENG. E.S.H.	5-30-00
CHK'D		APP'D E.S.H.	6-1-00

**CMS** 638 N. POINSETTA  
SANTA ANA, CA  
FAX (714) 664-0860  
COMPACT MANUFACTURING SYSTEMS

CAD DWG SIZE B E1-8055-02  
SCALE: NONE REF. DVG. SHEET 3 OF 16

EFFECTIVITY			REVISIONS			
S/N AND OP.	ZONE	REV	DESCRIPTION	E. C. NO	DATE	APPROVED
		A	CHANGED M-CODES		5-22-00	E.S.H.

049

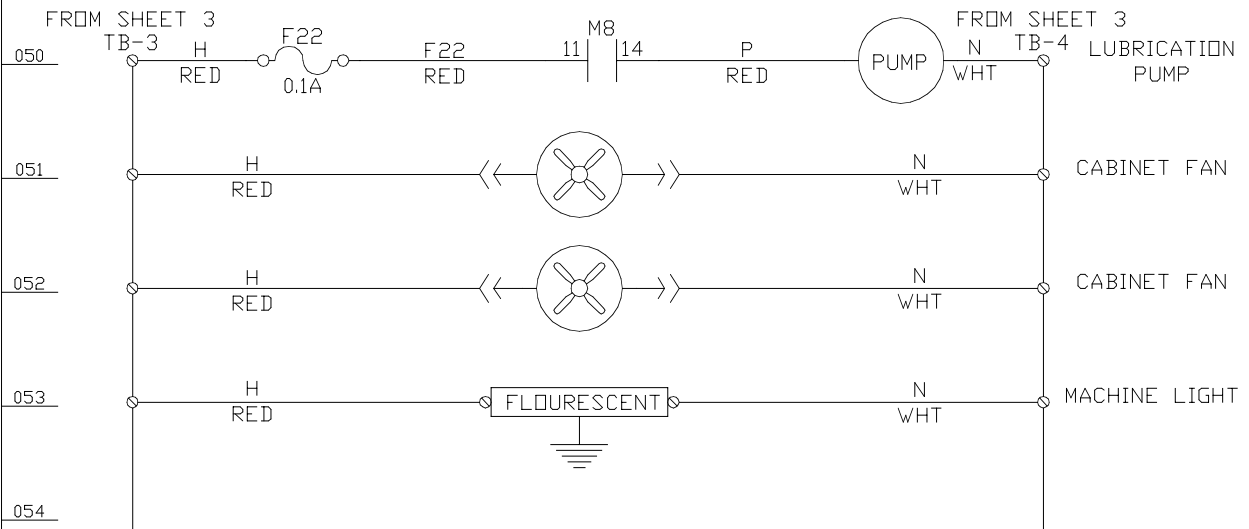

054

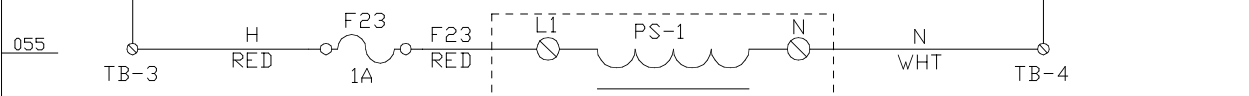

056

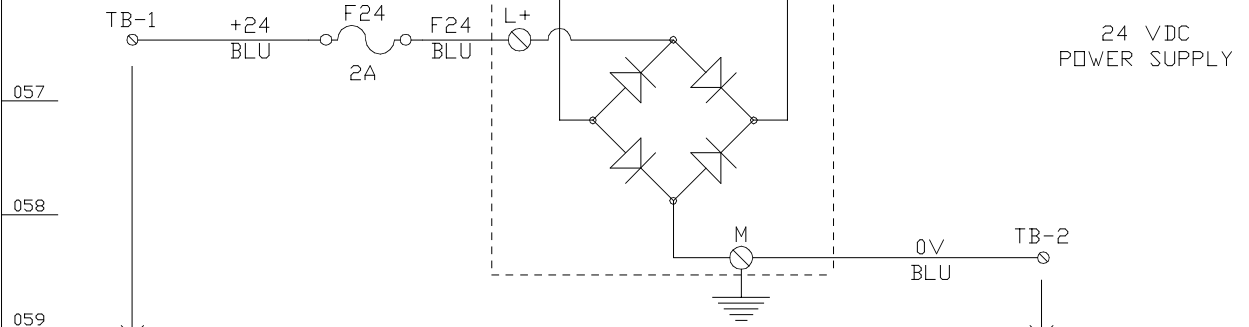

059

060

061

062

063

064

THE INFORMATION SHOWN HEREON IS PROPRIETARY DATA OF UPGRADE TECHNOLOGIES WITH ALL RIGHTS AND TITLES RESERVED AND IS NOT TO BE USED FOR PRODUCTION OF PARTS SHOWN EXCEPT BY WRITTEN PERMISSION OF UPGRADE TECHNOLOGIES					
NAME	DATE	NAME	DATE		
DRAWN G.W.M.	5-30-00	ENG. E.S.H.	5-30-00	638 N. POINSETTA SANTA ANA, CA FAX (714) 664-0860	
CHK'D		APP'D E.S.H.	6-1-00	COMPACT MANUFACTURING SYSTEMS	
TITLE			CAD DWG SIZE B		E1-8055-02A
FAGOR 8055 ELECTRICAL SCHEMATICS			SCALE: NONE		REF. DWG. SHEET 4 OF 16

EFFECTIVITY				REVISIONS			
S/N AND OP.	ZONE	REV	DESCRIPTION	E. C. NO	DATE	APPROVED	
		A	CHANGED M-CODES		5-22-00	E.S.H.	

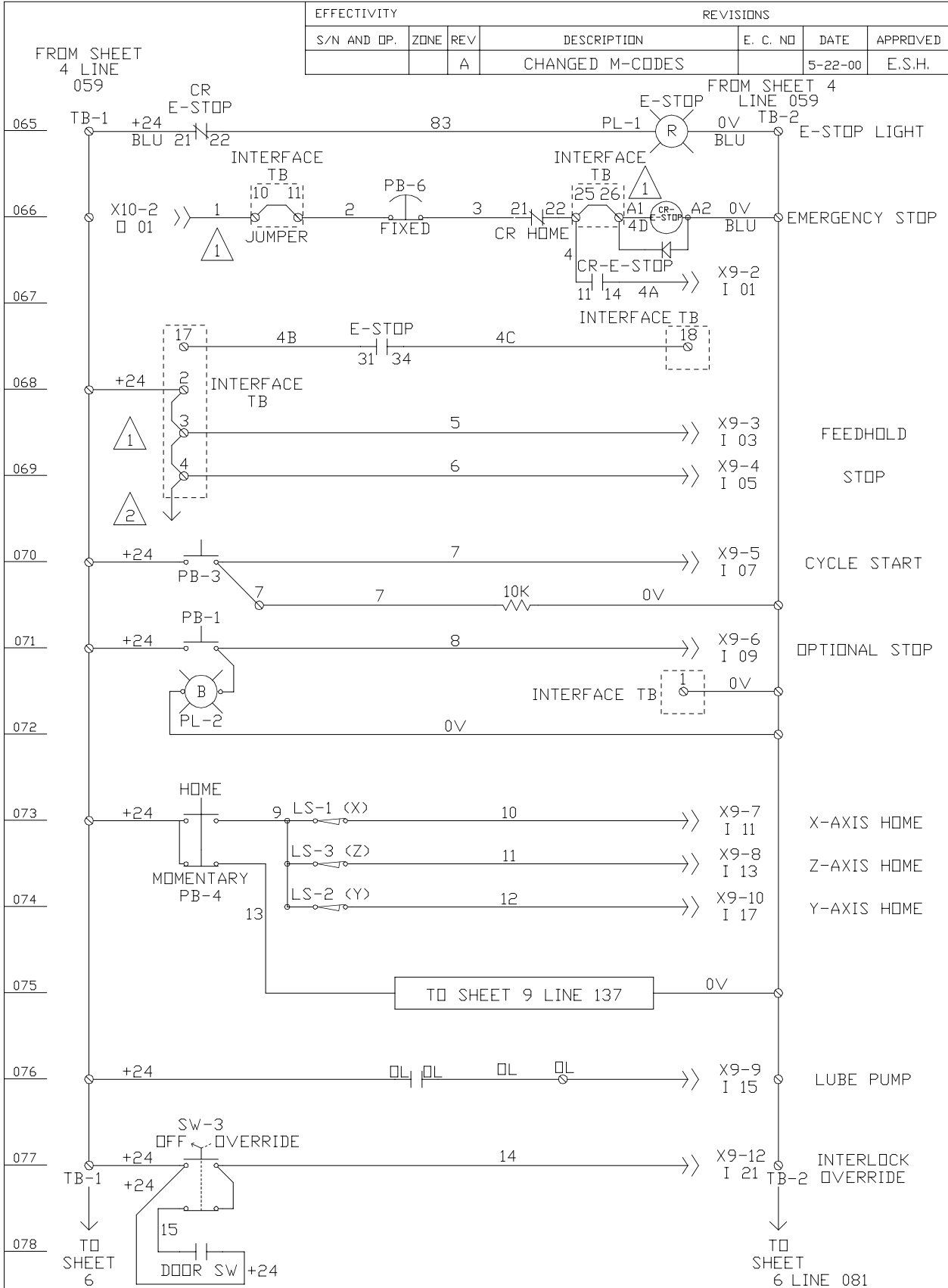

△ JUMPER CONTINUED ON SHEET 6 LINE

△ REMOVE JUMPER WHEN USING A BAR FEEDER

NOTE; ALL WIRES ARE BLUE

THE INFORMATION SHOWN HEREON IS PROPRIETARY DATA OF UPGRADE TECHNOLOGIES WITH ALL RIGHTS AND TITLES RESERVED AND IS NOT TO BE USED FOR PRODUCTION OF PARTS SHOWN EXCEPT BY WRITTEN PERMISSION OF UPGRADE TECHNOLOGIES							
DRAWN	G.W.M.	5-30-00	ENG.	E.S.H.	5-30-00	 638 N. POINSETTA SANTA ANA, CA FAX (714) 664-0860	
CHK'D			APP'D	E.S.H.	6-1-00		
TITLE				FAGOR 8055		E1-8055-03	
				ELECTRICAL SCHEMATICS		REF. DVG. SHEET 5 OF 16	

EFFECTIVITY			REVISIONS			
S/N AND OP.	ZONE	REV	DESCRIPTION	E. C. NO	DATE	APPROVED
		A	CHANGED M-CODES		5-22-00	E.S.H.

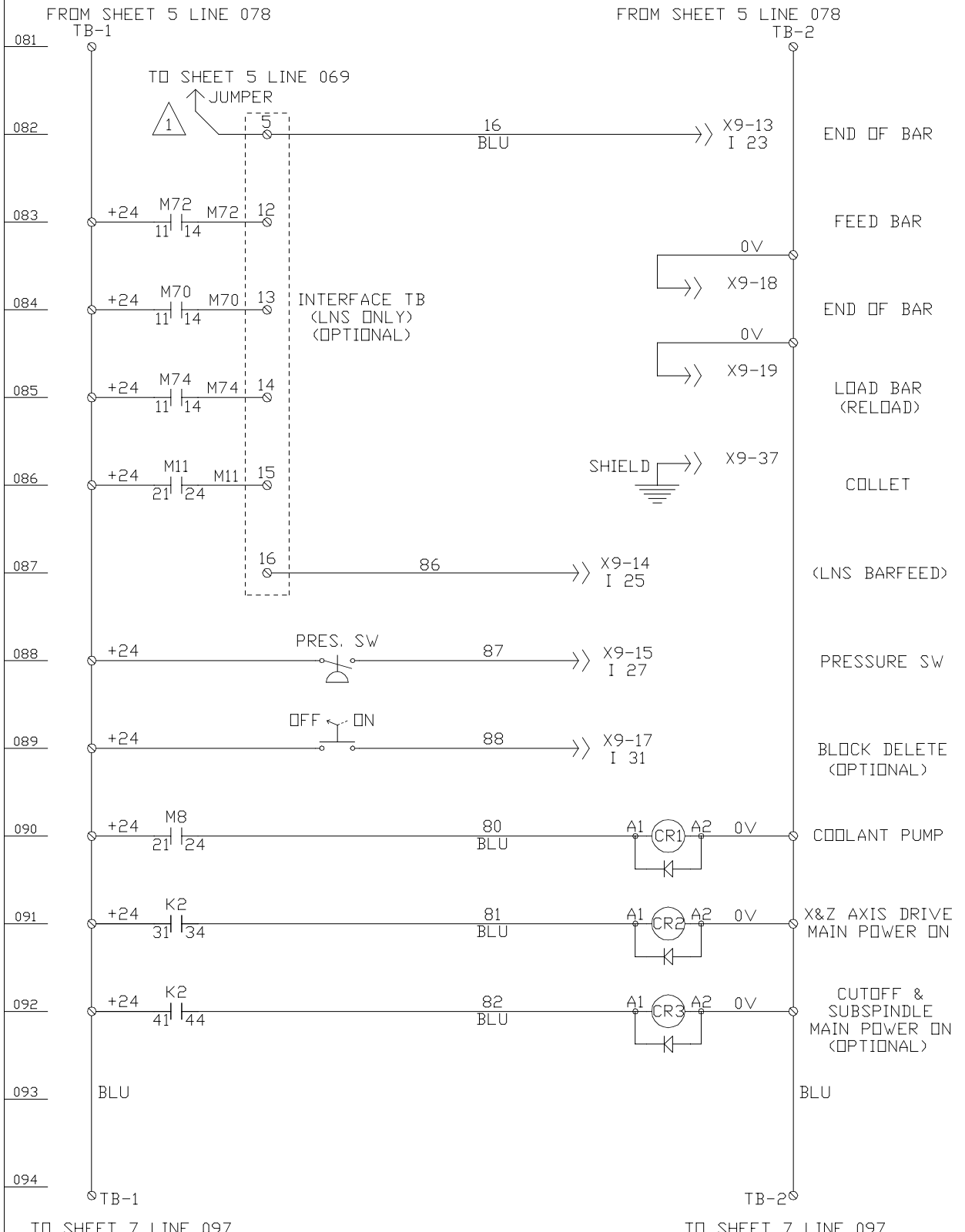

TO SHEET 7 LINE 097

TO SHEET 7 LINE 097

1 REMOVE JUMPER WHEN USING A BAR FEEDER

THE INFORMATION SHOWN HEREON IS PROPRIETARY DATA OF UPGRADE TECHNOLOGIES WITH ALL RIGHTS AND TITLES RESERVED AND IS NOT TO BE USED FOR PRODUCTION OF PARTS SHOWN EXCEPT BY WRITTEN PERMISSION OF UPGRADE TECHNOLOGIES					
NAME	DATE	NAME	DATE		
DRAWN G.W.M.	5-30-00	ENG. E.S.H.	5-30-00	638 N. POINSETTA SANTA ANA, CA FAX (714) 664-0860	
CHK'D		APP'D E.S.H.	6-1-00	COMPACT MANUFACTURING SYSTEMS	
TITLE			CAD DWG	SIZE	E1-8055-03A
FAGOR 8055 ELECTRICAL SCHEMATICS			SCALE: NONE	B	
				REF. DWG.	SHEET 6 OF 16

EFFECTIVITY			REVISIONS			
S/N AND OP.	ZONE	REV	DESCRIPTION	E. C. NO	DATE	APPROVED
		A	CHANGED M-CODES		5-22-00	E.S.H.

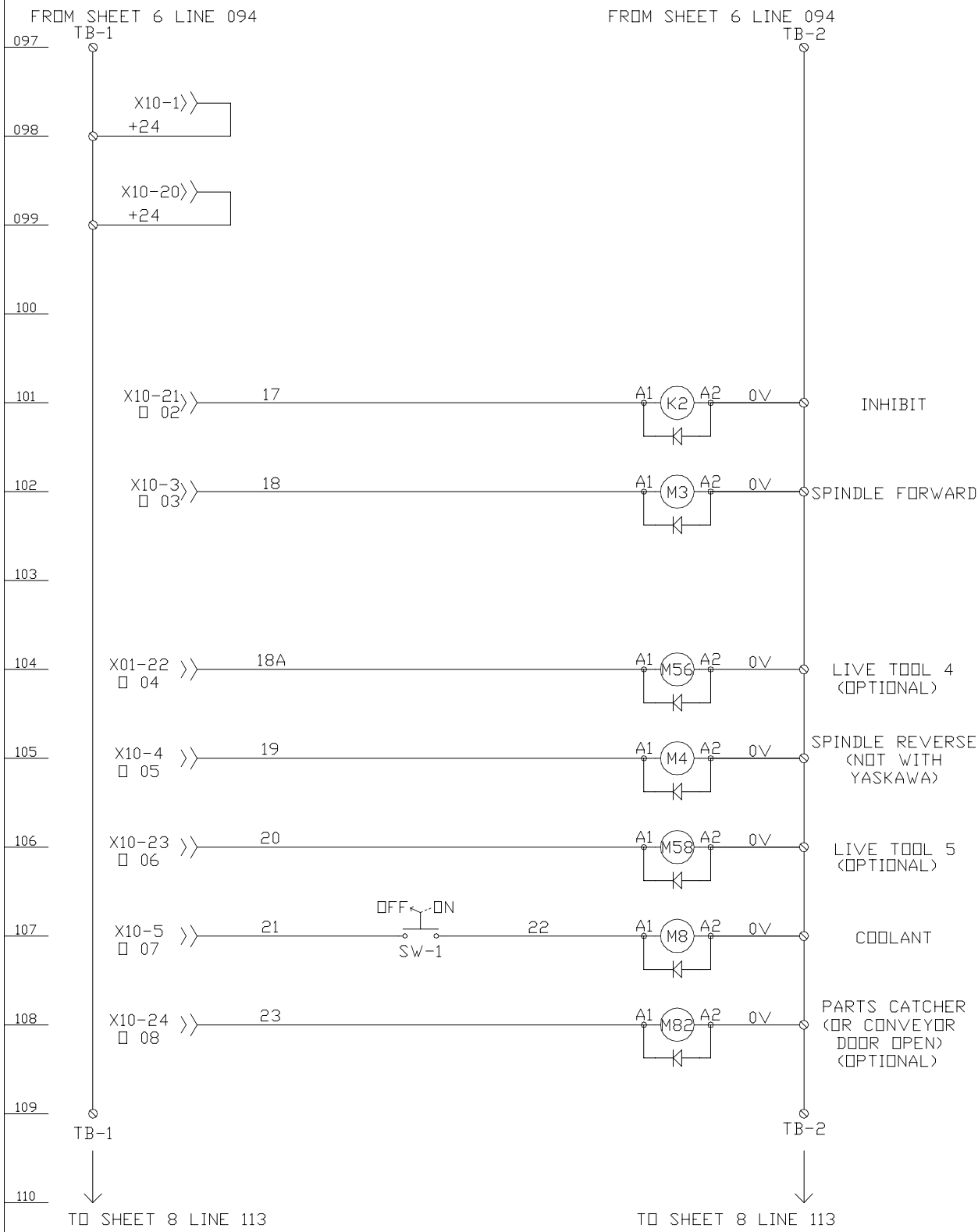

THE INFORMATION SHOWN HEREON IS PROPRIETARY DATA OF UPGRADE TECHNOLOGIES WITH ALL RIGHTS AND TITLES RESERVED AND IS NOT TO BE USED FOR PRODUCTION OF PARTS SHOWN EXCEPT BY WRITTEN PERMISSION OF UPGRADE TECHNOLOGIES					
NAME	DATE	NAME	DATE		
DRAWN G.W.M.	5-30-00	ENG. E.S.H.	5-30-00	638 N. POINSETTA SANTA ANA, CA FAX (714) 664-0860	
CHK'D		APP'D E.S.H.	6-1-00	COMPACT MANUFACTURING SYSTEMS	
TITLE			CAD DWG	SIZE B	E1-8055-04
FAGOR 8055 ELECTRICAL SCHEMATICS			SCALE: NONE	REF. DWG. SHEET 7 OF 16	

EFFECTIVITY			REVISIONS			
S/N AND OP.	ZONE	REV	DESCRIPTION	E. C. NO	DATE	APPROVED
		A	CHANGED M-CODES		5-22-00	E.S.H.

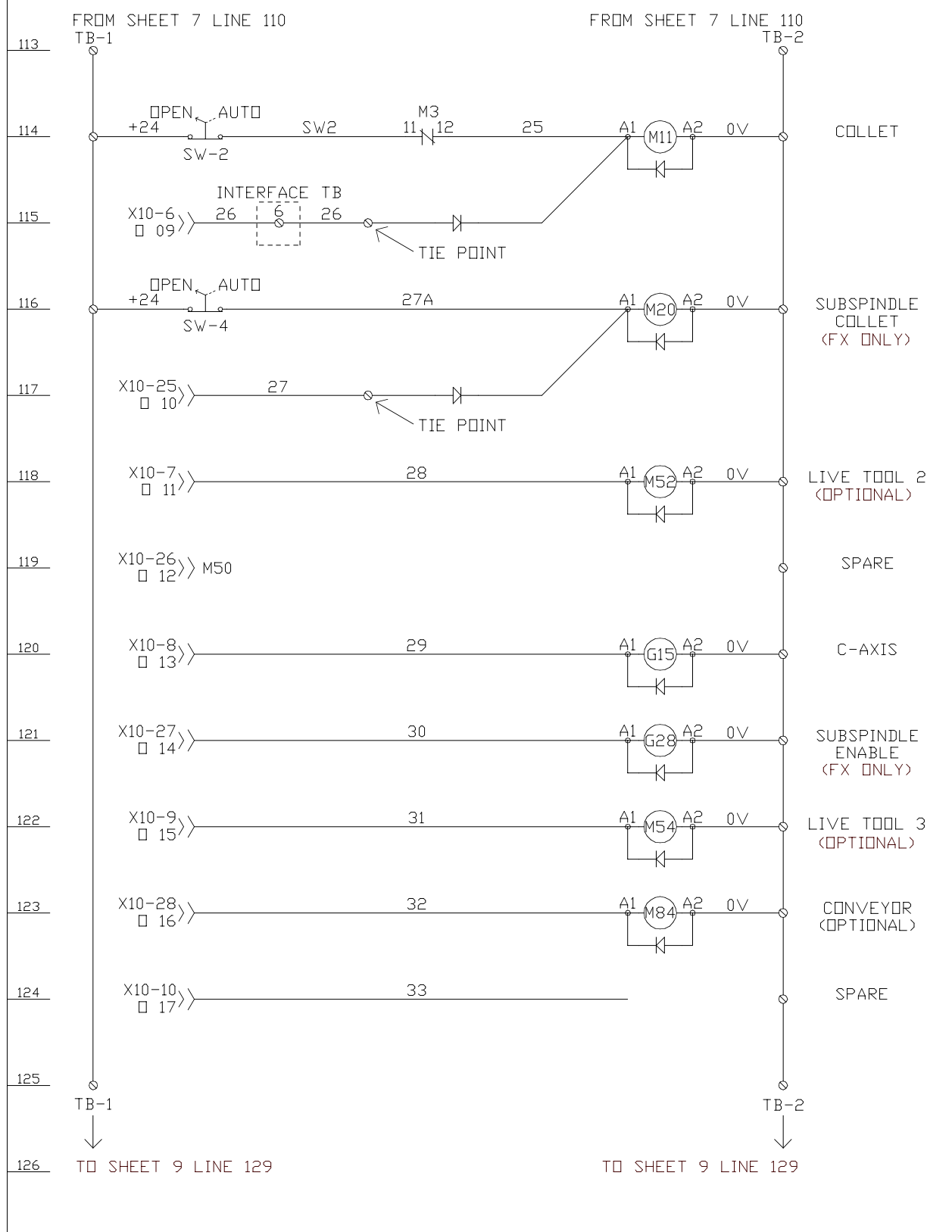

THE INFORMATION SHOWN HEREON IS PROPRIETARY DATA OF UPGRADE TECHNOLOGIES WITH ALL RIGHTS AND TITLES RESERVED AND IS NOT TO BE USED FOR PRODUCTION OF PARTS SHOWN EXCEPT BY WRITTEN PERMISSION OF UPGRADE TECHNOLOGIES

	NAME	DATE		NAME	DATE
DRAWN	G.W.M.	5-31-00	ENG.	E.S.H.	5-30-00
CHK'D			APP'D	E.S.H.	6-1-00

**CMS** 638 N. POINSETTA SANTA ANA, CA FAX (714) 664-0860  
COMPACT MANUFACTURING SYSTEMS

TITLE	FAGOR 8055 ELECTRICAL SCHEMATICS	CAD DWG	SIZE B	E1-8055-04A
SCALE	NONE	REF. DWG.	SHEET 8 OF 16	

127

128

3 RELAY IS REQUIRED ONLY WHEN USING A BAR FEEDER

EFFECTIVITY			REVISIONS			
S/N AND OP.	ZONE	REV	DESCRIPTION	E. C. NO	DATE	APPROVED
		A	CHANGED M-CODES		5-22-00	E.S.H.

FROM SHEET 8 LINE 126

FROM SHEET 8 LINE 126

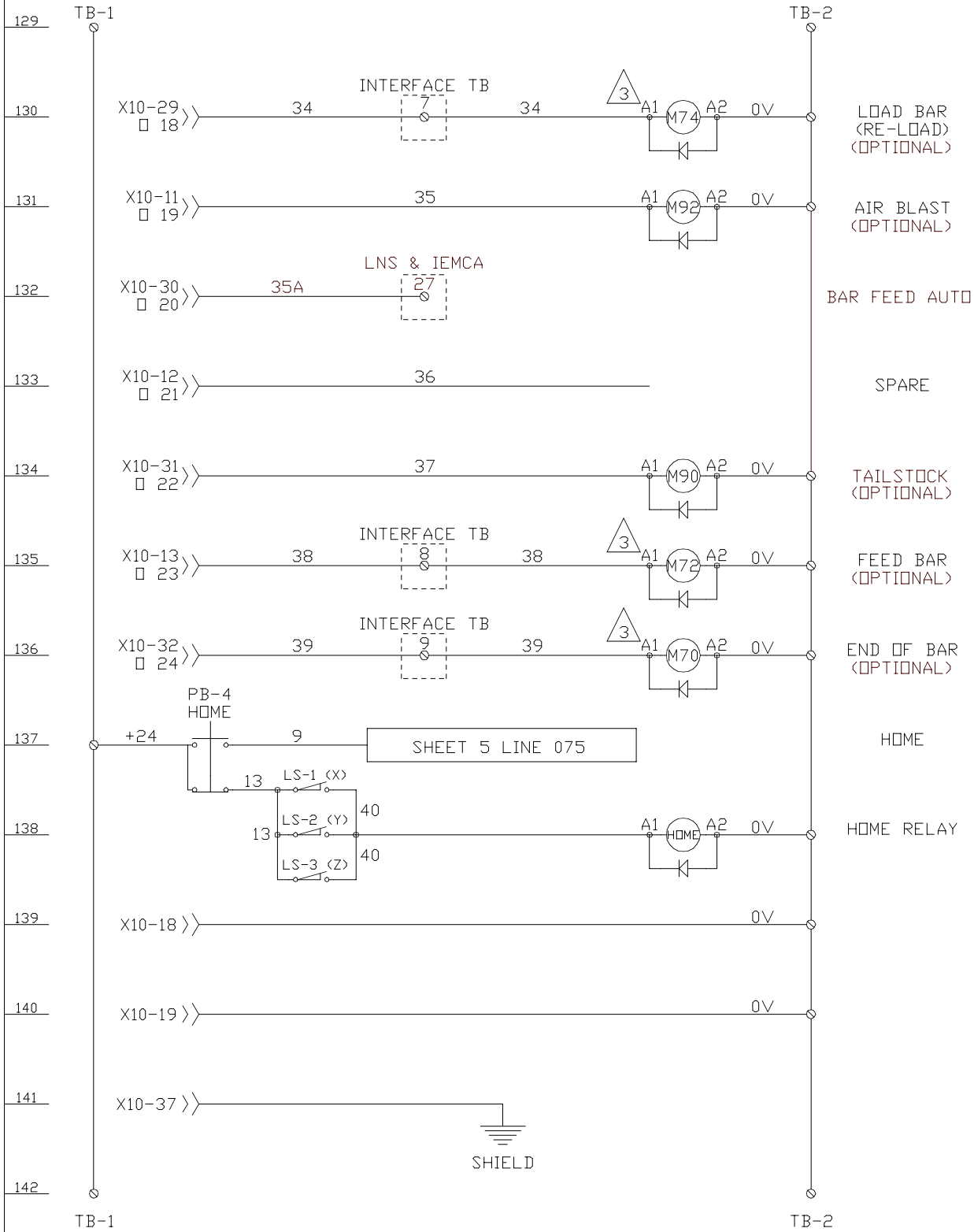

THE INFORMATION SHOWN HEREON IS PROPRIETARY DATA OF UPGRADE TECHNOLOGIES WITH ALL RIGHTS AND TITLES RESERVED AND IS NOT TO BE USED FOR PRODUCTION OF PARTS SHOWN EXCEPT BY WRITTEN PERMISSION OF UPGRADE TECHNOLOGIES					
NAME	DATE	NAME	DATE		
DRAWN G.W.M.	5-31-00	ENG. E.S.H.	5-30-00	638 N. POINSETTA SANTA ANA, CA FAX (714) 664-0860	
CHK'D		APP'D E.S.H.	6-1-00	COMPACT MANUFACTURING SYSTEMS	
TITLE			CAD DWG	SIZE	E1-8055-04B
FAGOR 8055 ELECTRICAL SCHEMATICS				B	
				SCALE: NONE	REF. DWG. SHEET 9 OF 16

EFFECTIVITY			REVISIONS			
S/N AND OP.	ZONE	REV	DESCRIPTION	E. C. NO	DATE	APPROVED
		A	CHANGED M-CODES		5-22-00	E.S.H.

145

BALDOR SPINDLE DRIVE

146

147

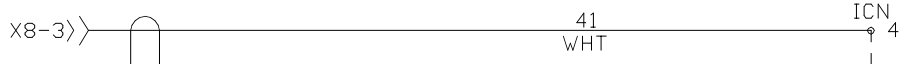

SPINDLE SIGNAL

148



149

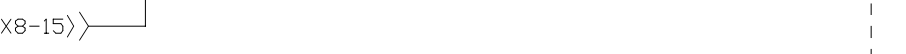

150



SPINDLE LOCK/FREE

151



FORWARD

152



REVERSE

153



SIGNAL COMMON

BALDOR CONTROL BOARD

154



BRAKE

155



156

157

158

159

THE INFORMATION SHOWN HEREON IS PROPRIETARY DATA OF UPGRADE TECHNOLOGIES WITH ALL RIGHTS AND TITLES RESERVED AND IS NOT TO BE USED FOR PRODUCTION OF PARTS SHOWN EXCEPT BY WRITTEN PERMISSION OF UPGRADE TECHNOLOGIES										
	NAME	DATE		NAME	DATE	638 N. POINSETTA SANTA ANA, CA FAX (714) 664-0860				
DRAWN	G.W.M.	6-8-00	ENG.	E.S.H.	5-30-00					
CHK'D			APP'D	E.S.H.	6-9-00	COMPACT MANUFACTURING SYSTEMS				
TITLE						CAD DWG	SIZE	E1-8055-B-06		
FAGOR 8055 ELECTRICAL SCHEMATICS						SCALE: NONE	B			
						REF. DWG.		SHEET 10 OF 16		

160

EFFECTIVITY			REVISIONS			
S/N AND OP.	ZONE	REV	DESCRIPTION	E. C. NO	DATE	APPROVED
		A	CHANGED M-CODES		5-22-00	E.S.H.

145

DELTA SPINDLE DRIVE

146

147

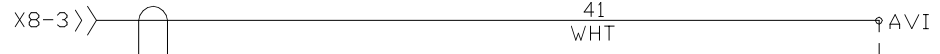

SPINDLE SIGNAL

148



149



150

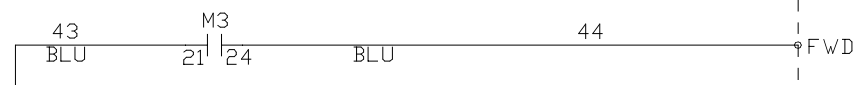

FORWARD

151

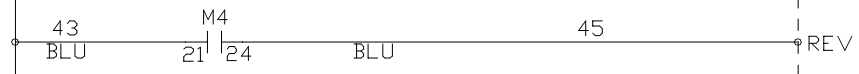

REVERSE

152



SIGNAL COMMON

DELTA CONTROL BOARD

153

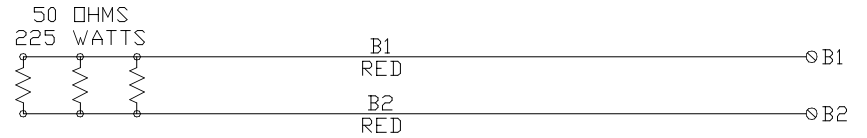

BRAKE

156

157

158

159

THE INFORMATION SHOWN HEREON IS PROPRIETARY DATA OF UPGRADE TECHNOLOGIES WITH ALL RIGHTS AND TITLES RESERVED AND IS NOT TO BE USED FOR PRODUCTION OF PARTS SHOWN EXCEPT BY WRITTEN PERMISSION OF UPGRADE TECHNOLOGIES									
	NAME	DATE		NAME	DATE	638 N. POINSETTA SANTA ANA, CA FAX (714) 664-0860			
DRAWN	G.W.M.	6-8-00	ENG.	E.S.H.	5-22-00				
CHK'D			APP'D	E.S.H.	6-9-00	CAD DWG	SIZE B	E1-8055-D-06	
TITLE FAGOR 8055 ELECTRICAL SCHEMATICS						SCALE: NONE	REF. DWG. SHEET 10 OF 16		

160

EFFECTIVITY			REVISIONS			
S/N AND OP.	ZONE	REV	DESCRIPTION	E. C. NO	DATE	APPROVED
		A	CHANGED M-CODES		5-22-00	E.S.H.

EMS SPINDLE DRIVE

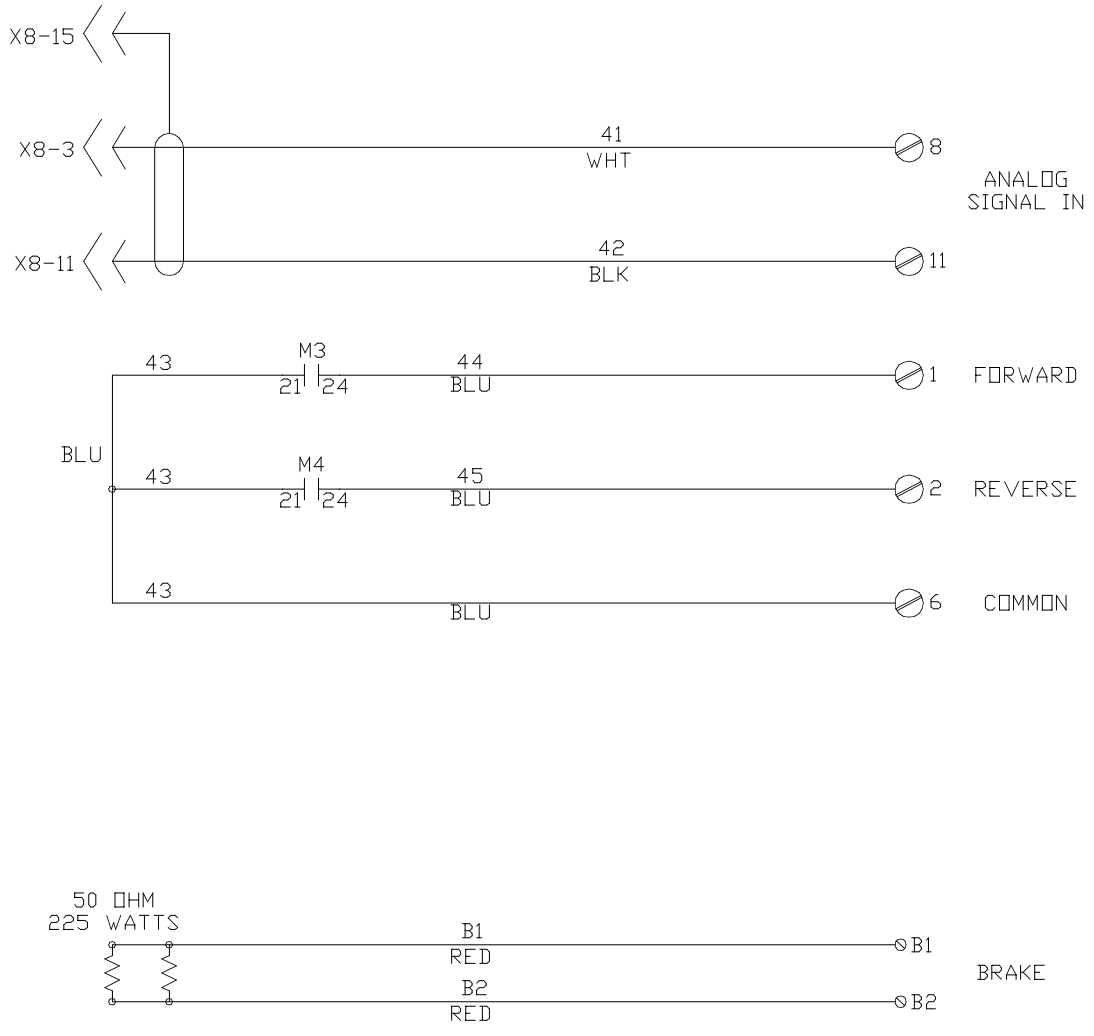

THE INFORMATION SHOWN HEREON IS PROPRIETARY DATA OF UPGRADE TECHNOLOGIES WITH ALL RIGHTS AND TITLES RESERVED AND IS NOT TO BE USED FOR PRODUCTION OF PARTS SHOWN EXCEPT BY WRITTEN PERMISSION OF UPGRADE TECHNOLOGIES										
	NAME	DATE		NAME	DATE	 638 N. POINSETTA SANTA ANA, CA FAX (714) 664-0860				
DRAWN	G.W.M.	6-7-00	ENG.	E.S.H.	5-22-00			COMPACT MANUFACTURING SYSTEMS		
CHK'D			APP'D	E.S.H.	6-9-00	CAD DWG	SIZE B	E1-8055-E-06		
TITLE FAGOR 8055 ELECTRICAL SCHEMATICS							SCALE: NONE	REF. DVG. SHEET 10 OF 16		

EFFECTIVITY			REVISIONS			
S/N AND OP.	ZONE	REV	DESCRIPTION	E. C. NO	DATE	APPROVED
		A	CHANGED M-CODES		5-22-00	E.S.H.

YASKAWA INVERTER FOR INDEXING - NO C-AXIS

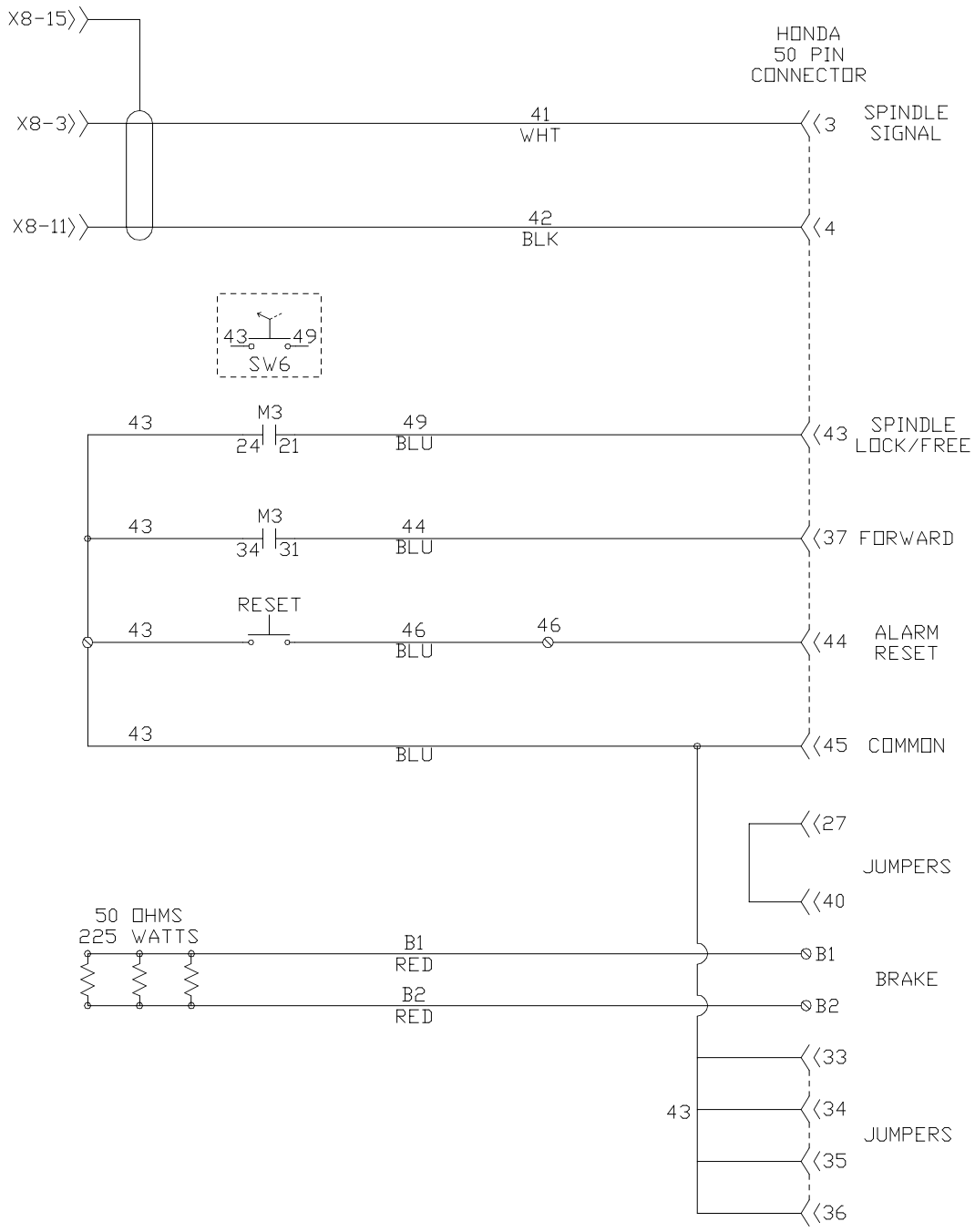

THE INFORMATION SHOWN HEREON IS PROPRIETARY DATA OF UPGRADE TECHNOLOGIES WITH ALL RIGHTS AND TITLES RESERVED AND IS NOT TO BE USED FOR PRODUCTION OF PARTS SHOWN EXCEPT BY WRITTEN PERMISSION OF UPGRADE TECHNOLOGIES										
	NAME	DATE		NAME	DATE	 638 N. POINSETTA SANTA ANA, CA FAX (714) 664-0860				
DRAWN	G.W.M.	5-31-00	ENG.	E.S.H.	5-22-00					
CHK'D			APP'D	E.S.H.	6-9-00	COMPACT MANUFACTURING SYSTEMS				
TITLE						CAD DWG	SIZE	E1-8055-Y4-06		
FAGOR 8055 ELECTRICAL SCHEMATICS							B			
						SCALE: NONE	REF. DWG.	SHEET 10 OF 16		

EFFECTIVITY				REVISIONS			
S/N AND OP.	ZONE	REV	DESCRIPTION	E. C. NO	DATE	APPROVED	
		A	CHANGED M-CODES		5-22-00	E.S.H.	

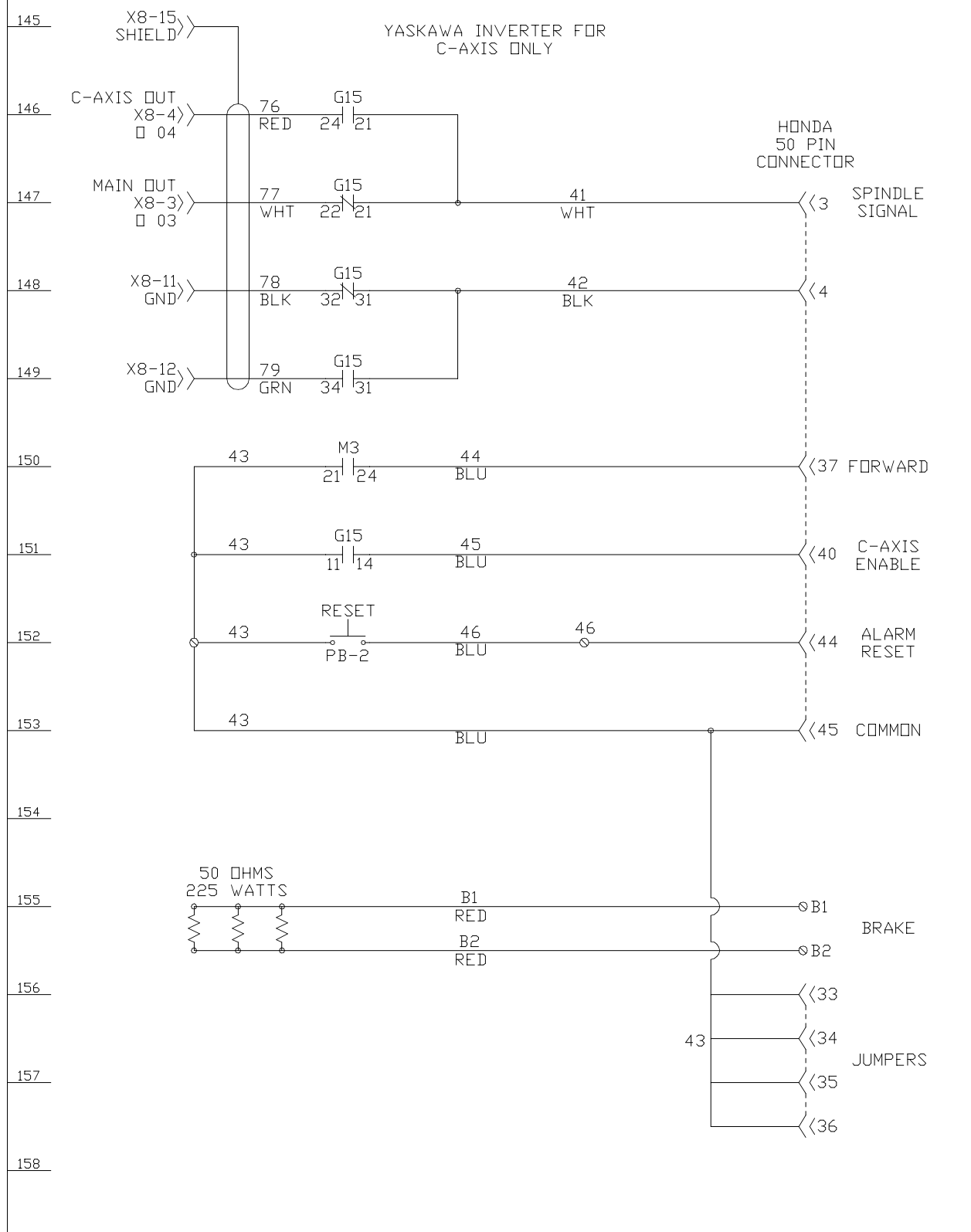

THE INFORMATION SHOWN HEREON IS PROPRIETARY DATA OF UPGRADE TECHNOLOGIES WITH ALL RIGHTS AND TITLES RESERVED AND IS NOT TO BE USED FOR PRODUCTION OF PARTS SHOWN EXCEPT BY WRITTEN PERMISSION OF UPGRADE TECHNOLOGIES							
NAME	DATE	NAME	DATE	 638 N. POINSETTA SANTA ANA, CA FAX (714) 664-0860			
DRAWN G.W.M.	5-31-00	ENG. E.S.H.	5-30-00	COMPACT MANUFACTURING SYSTEMS			
CHK'D		APP'D E.S.H.	6-1-00	CAD DWG	SIZE B	E1-8055-Y-10	
TITLE FAGOR 8055 ELECTRICAL SCHEMATICS				SCALE: NONE	REF. DWG. SHEET 10 OF 16		

EFFECTIVITY				REVISIONS			
S/N AND OP.	ZONE	REV	DESCRIPTION	E. C. NO	DATE	APPROVED	
		A	CHANGED M-CODES		5-22-00	E.S.H.	

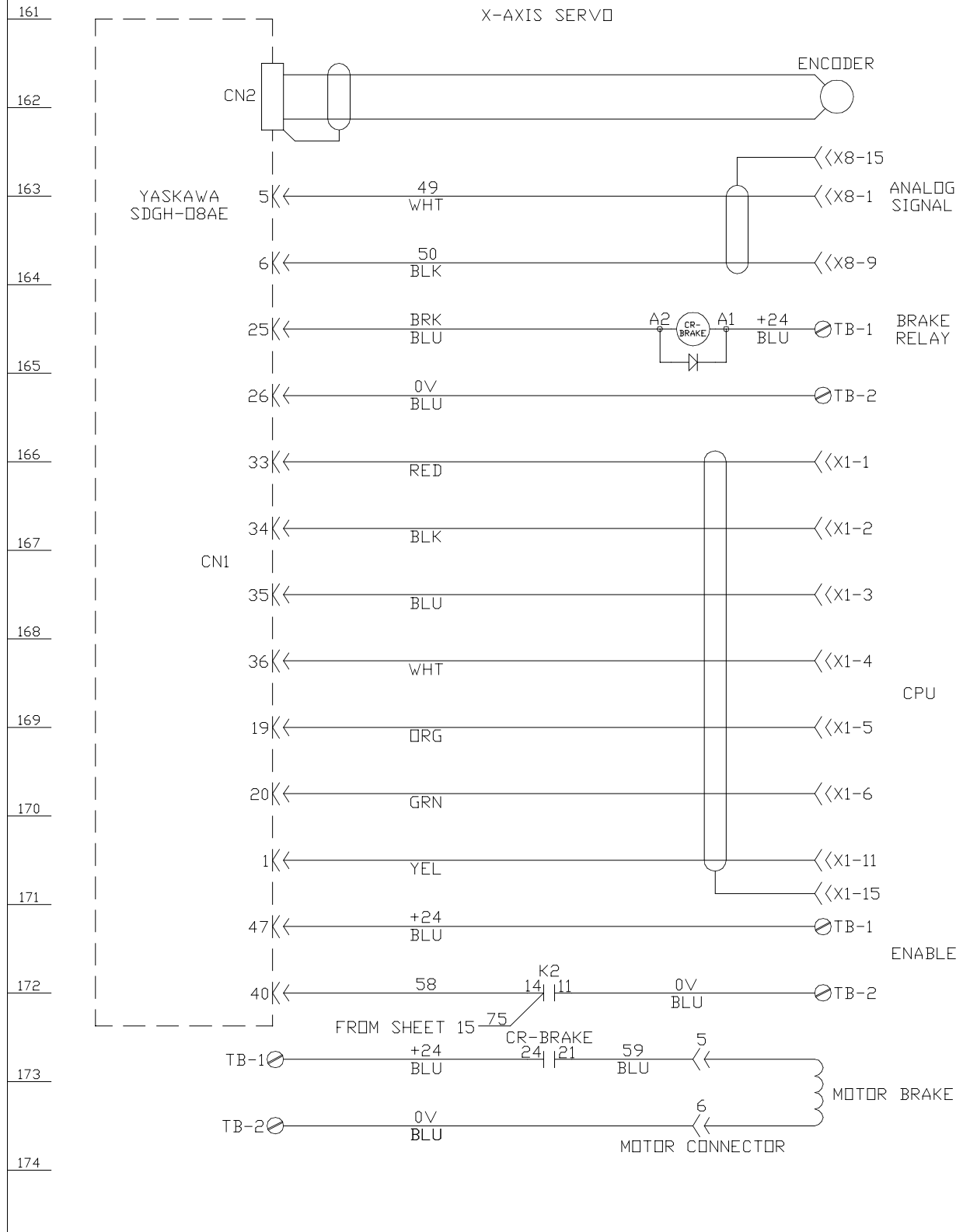

THE INFORMATION SHOWN HEREON IS PROPRIETARY DATA OF UPGRADE TECHNOLOGIES WITH ALL RIGHTS AND TITLES RESERVED AND IS NOT TO BE USED FOR PRODUCTION OF PARTS SHOWN EXCEPT BY WRITTEN PERMISSION OF UPGRADE TECHNOLOGIES							
NAME	DATE	NAME	DATE	<b>CMS</b> 638 N. POINSETTA SANTA ANA, CA FAX (714) 664-0860 COMPACT MANUFACTURING SYSTEMS			
DRAWN	G.W.M. 5-31-00	ENG.	E.S.H. 5-30-00				
CHK'D		APP'D	E.S.H. 6-1-00	CAD DWG	SIZE B	E1-8055-4-07	
TITLE FAGOR 8055 ELECTRICAL SCHEMATICS				SCALE: NONE	REF. DWG. SHEET 11 OF 16		

175

176

EFFECTIVITY				REVISIONS			
S/N AND OP.	ZONE	REV	DESCRIPTION	E. C. NO	DATE	APPROVED	
		A	CHANGED M-CODES		5-22-00	E.S.H.	

Z-AXIS SERVO

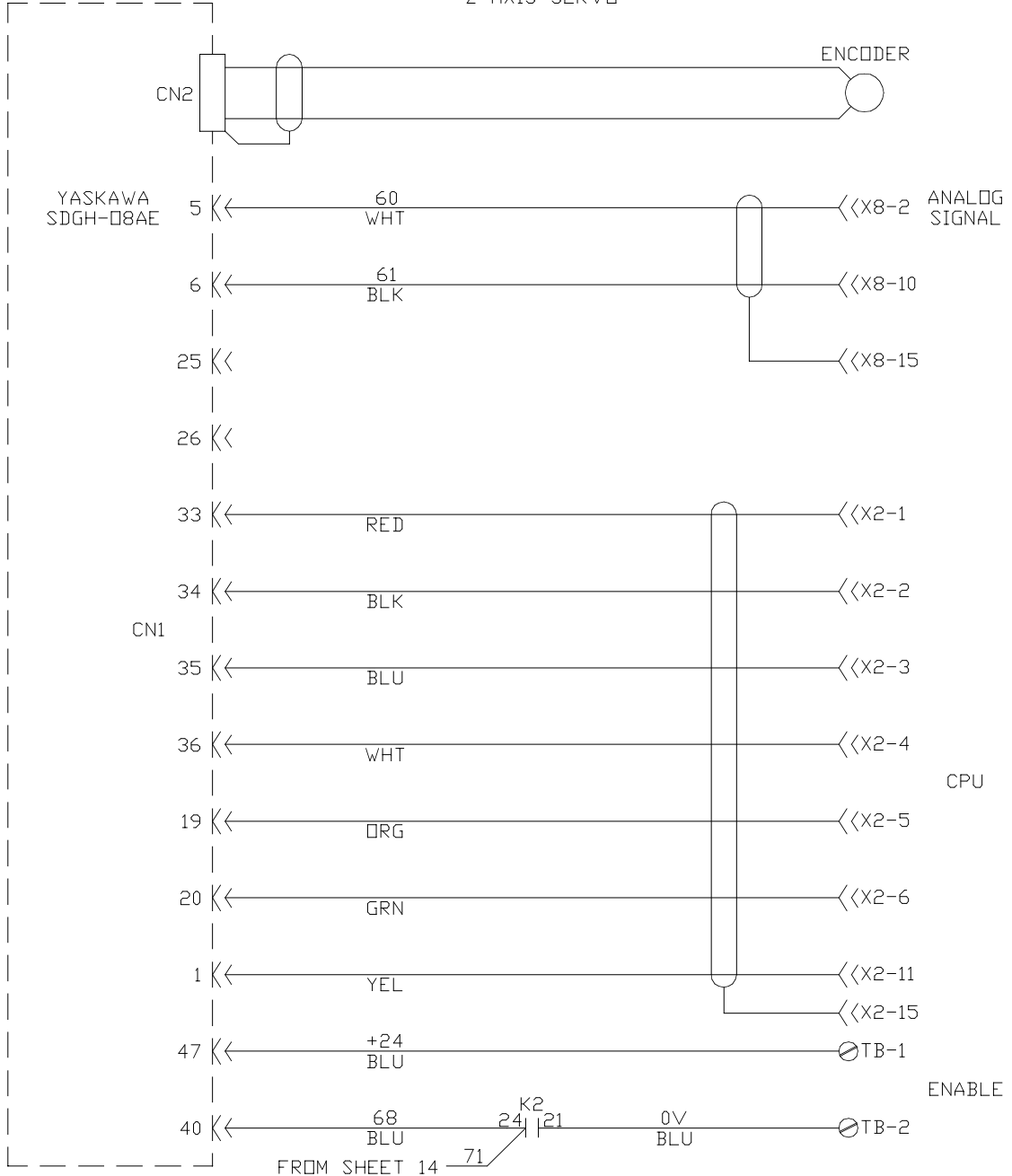

THE INFORMATION SHOWN HEREON IS PROPRIETARY DATA OF UPGRADE TECHNOLOGIES WITH ALL RIGHTS AND TITLES RESERVED AND IS NOT TO BE USED FOR PRODUCTION OF PARTS SHOWN EXCEPT BY WRITTEN PERMISSION OF UPGRADE TECHNOLOGIES											
NAME	DATE	NAME	DATE	CMS		638 N. POINSETTA SANTA ANA, CA FAX (714) 664-0860					
DRAWN	G.W.M.	5-31-00	ENG.	E.S.H.	5-30-00	COMPACT MANUFACTURING SYSTEMS					
CHK'D			APP'D	E.S.H.	6-1-00	CAD DWG	SIZE	E1-8055-4-09			
TITLE						SCALE	REF. DWG.	SHEET 12 OF 16			
FAGOR 8055 ELECTRICAL SCHEMATICS						NONE					

EFFECTIVITY				REVISIONS			
S/N AND OP.	ZONE	REV	DESCRIPTION	E. C. NO	DATE	APPROVED	
		A	CHANGED M-CODES		5-22-00	E.S.H.	

Y-AXIS CUTOFF SERVO

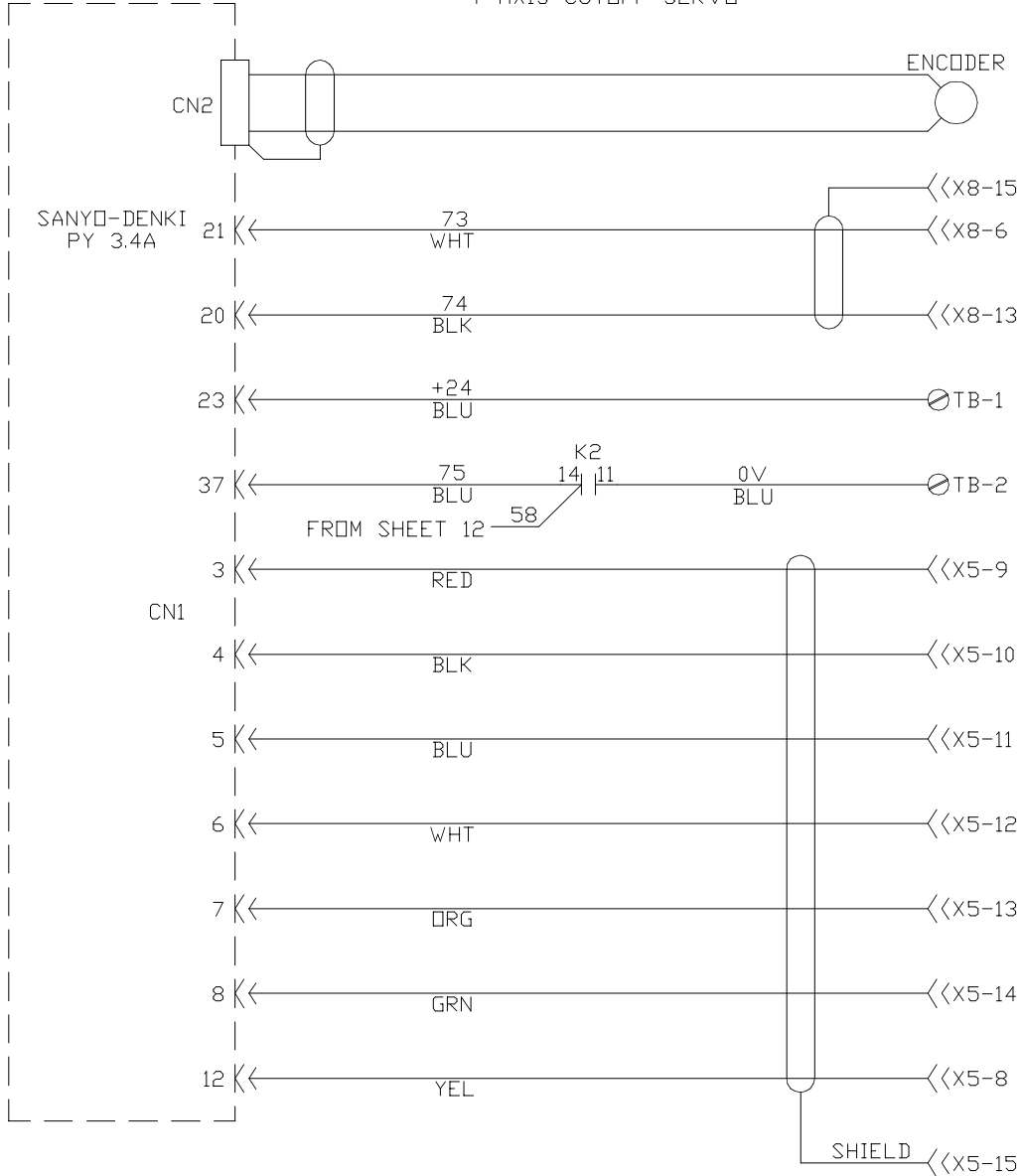

THE INFORMATION SHOWN HEREON IS PROPRIETARY DATA OF UPGRADE TECHNOLOGIES WITH ALL RIGHTS AND TITLES RESERVED AND IS NOT TO BE USED FOR PRODUCTION OF PARTS SHOWN EXCEPT BY WRITTEN PERMISSION OF UPGRADE TECHNOLOGIES											
NAME	DATE	NAME	DATE	638 N. POINSETTA SANTA ANA, CA FAX (714) 664-0860							
DRAWN	G.W.M.	5-31-00	ENG.								
CHK'D			APP'D	E.S.H.	6-1-00	COMPACT MANUFACTURING SYSTEMS		CAD DWG		SIZE	E1-8055-5-08
TITLE						SCALE: NONE		REF. DWG.		SHEET 13 OF 16	
FAGOR 8055											
ELECTRICAL SCHEMATICS											

EFFECTIVITY				REVISIONS			
S/N AND OP.	ZONE	REV	DESCRIPTION	E. C. NO	DATE	APPROVED	
		A	CHANGED M-CODES		5-22-00	E.S.H.	

SUBSPINDLE SERVO

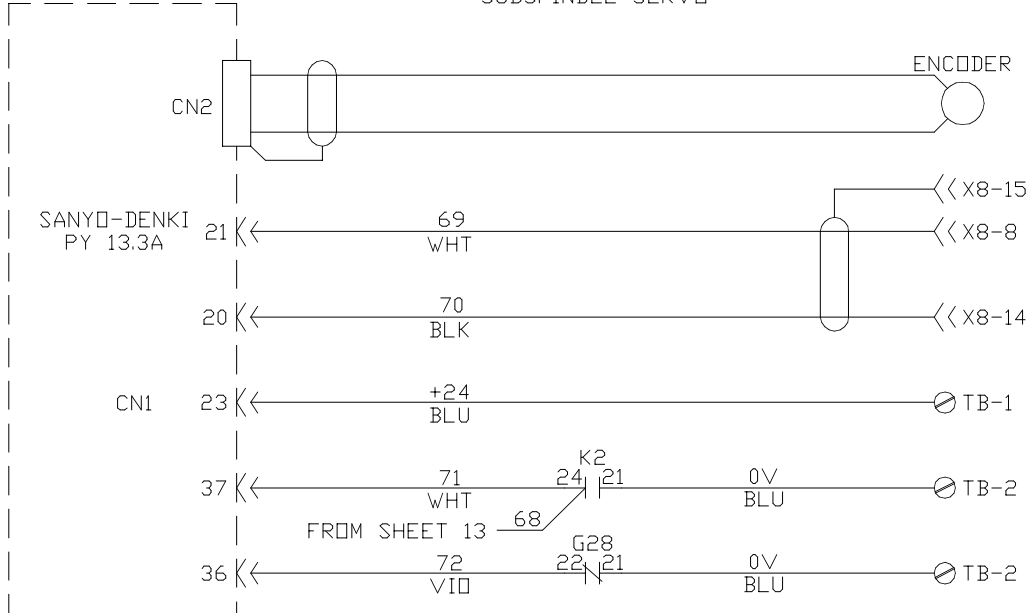

209  
210  
211  
212  
213  
214  
215  
216  
217  
218  
219  
220  
221  
222

THE INFORMATION SHOWN HEREON IS PROPRIETARY DATA OF UPGRADE TECHNOLOGIES WITH ALL RIGHTS AND TITLES RESERVED AND IS NOT TO BE USED FOR PRODUCTION OF PARTS SHOWN EXCEPT BY WRITTEN PERMISSION OF UPGRADE TECHNOLOGIES												
NAME	DATE	NAME	DATE	 638 N. POINSETTA SANTA ANA, CA FAX (714) 664-0860								
DRAWN	G.W.M.	5-31-00	ENG.									E.S.H.
CHK'D			APP'D	E.S.H.	6-1-00	COMPACT MANUFACTURING SYSTEMS						
TITLE				FAGOR 8055 ELECTRICAL SCHEMATICS				CAD DWG	SIZE	E1-8055-5-14		
								SCALE	NONE	REF. DWG. SHEET 14 OF 16		

223  
224

EFFECTIVITY				REVISIONS			
S/N AND OP.	ZONE	REV	DESCRIPTION	E. C. NO	DATE	APPROVED	
		A	CHANGED M-CODES		5-22-00	E.S.H.	

8055 MAIN SPINDLE ENCODER                      FAGOR CPU

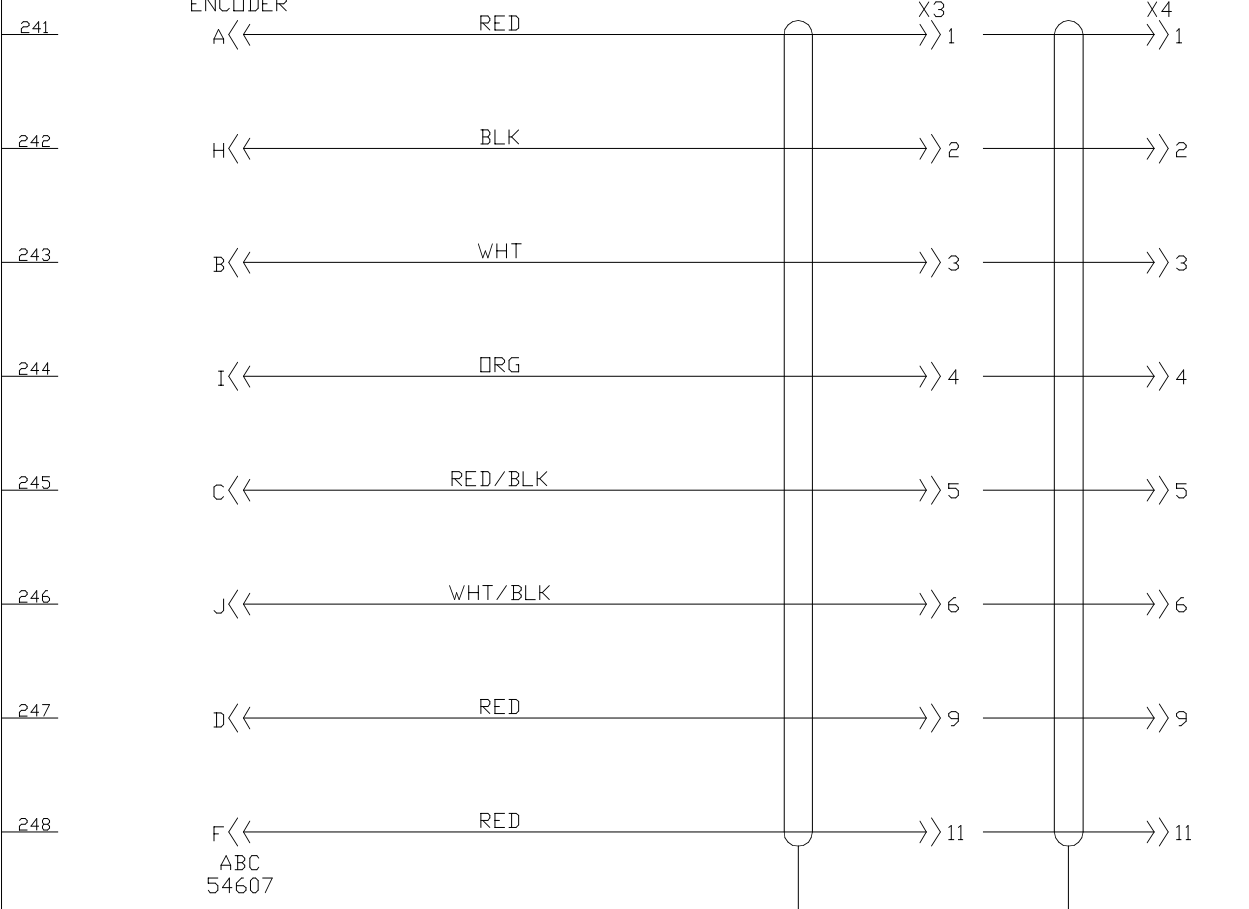

NOTE; THE X4 CONNECTOR IS FOR C AXIS ONLY. X3 AND X4 ARE WIRED TO THE SAME PINS ON THE ENCODER CABLE

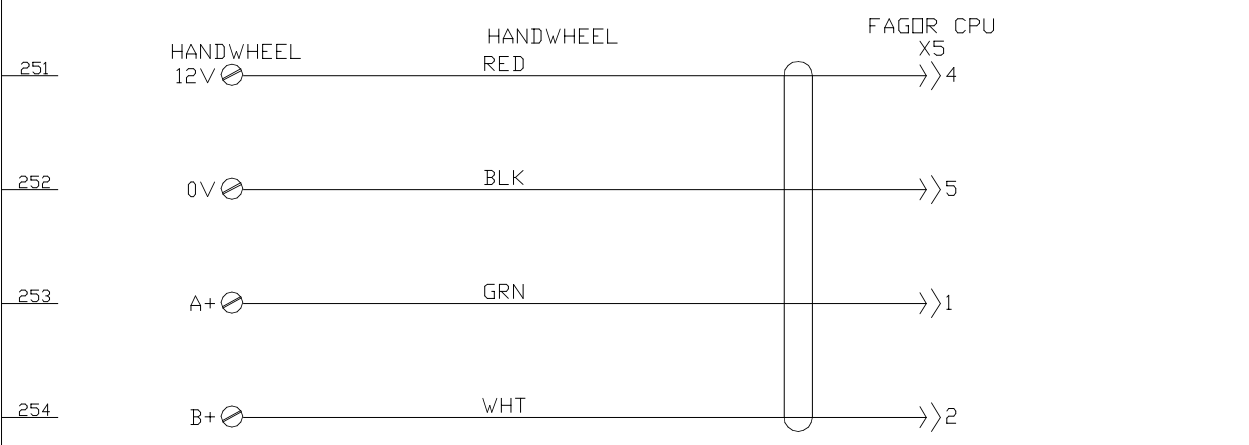

THE INFORMATION SHOWN HEREON IS PROPRIETARY DATA OF UPGRADE TECHNOLOGIES WITH ALL RIGHTS AND TITLES RESERVED AND IS NOT TO BE USED FOR PRODUCTION OF PARTS SHOWN EXCEPT BY WRITTEN PERMISSION OF UPGRADE TECHNOLOGIES														
DRAWN			NAME			DATE			NAME			DATE		
G.W.M.			6-22-00			ENG.			E.S.H.			6-22-00		
CHK'D			APP'D			E.S.H.			6-22-00			COMPACT MANUFACTURING SYSTEMS		
TITLE						SIZE			REF. DWG.			SHEET 16 OF 16		
SPINDLE ENCODER & HANDWHEEL						B			E1-8055-70			SCALE: NONE		

**CMS**  
 638 N. POINSETTA  
 SANTA ANA, CA  
 FAX (714) 664-0860